

Highland Tanks Pty Ltd trading as

Ultra Clear

Wastewater Treatment Systems

ABN 93 090 907 725

PO Box 1158, MITTAGONG NSW 2575

Phone: 02 4871 2156

Model ST8

Aerated Wastewater Treatment System suitable to deal with WC's and all waste on residential premises

Drawn & Designed by: DW Rebbeck
UCST8SD 56 Revision 1 21/09/2020

No.	Capacity	Description
1	1570 litres	Primary Chamber 1
2	780 litres	Primary Chamber 2
3	1120 litres	Aerobic Chamber 1
4	1120 litres	Aerobic Chamber 2
5	400 litres	Settling Chamber
6/7	360 litres	Disinfection Pump Chamber
	5350 litres	Total Capacity

No.	Description Parts	No.	Description Parts
A	Flow pipe primary to aeration	F	Pump ledge and pump
B	Inlet square	G	Air line and diffuser
C	Sludge return pipe	H	Media pack
D	Flow pipe aeration to settling chamber	I	Blower and electrical housing cover
E	Chlorinator	J	Chlorine adjustor

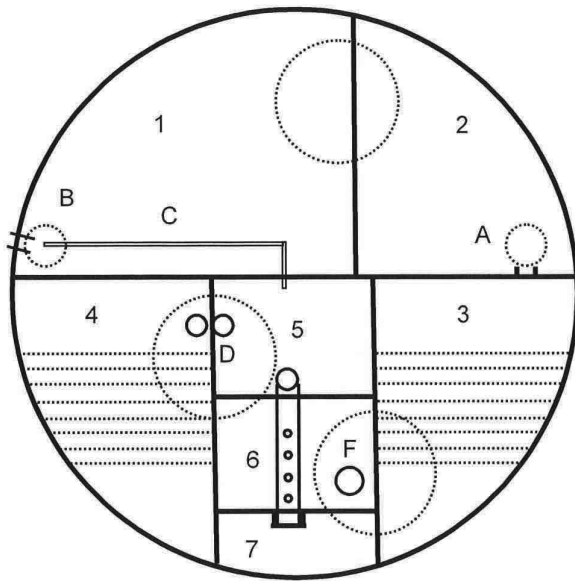

2495

ACCREDITED
- 6 NOV 2020
NSW MINISTRY OF HEALTH

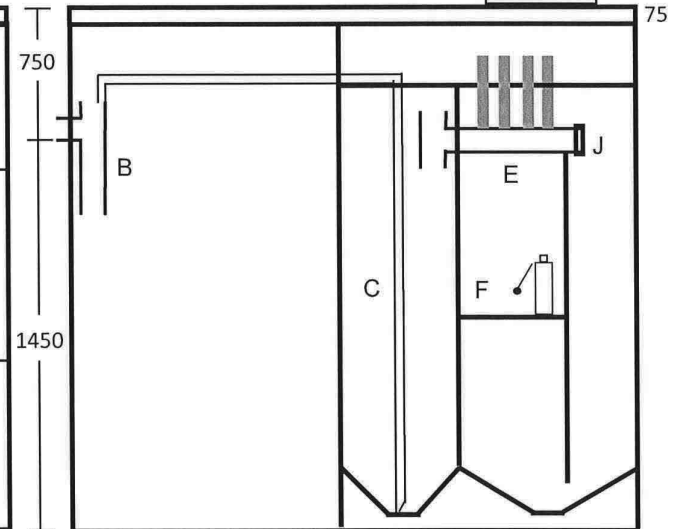
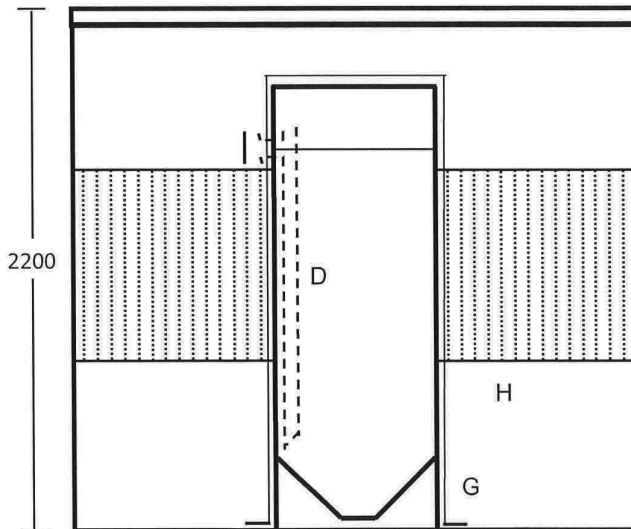

Collection wells manufactured by **Highland Tanks**
PO Box 1158, MITTAGONG NSW 2575
16 Gantry Place, BRAEMAR NSW 2575
Phone: 02 4871 2156

All Septic Tanks & Collection Wells are manufactured to comply with Australian Standards AS/NZS 1546.1:2008
All internal and sundries supplied by
Ultra Clear Wastewater Treatment Systems